



Part # 11535010

1963-1982 Corvette StreetGrip Kit

Front Components

11539590	Delrin Control Arm Bushings
11532350	Front Dual Rate Coil Springs
11539120	Front Sway Bar

Rear Components

11534799	Composite Leaf Spring
----------	-----------------------

Shock Kit

11530110	Front & Rear HQ Series Shocks
----------	-------------------------------

Recommended Tools

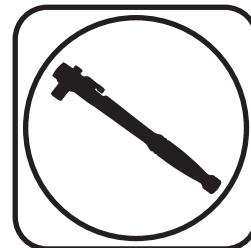
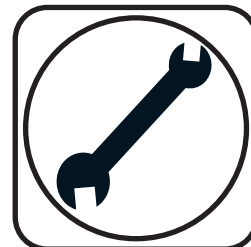

1963-1982 Corvette Street Grip Installation Instructions

Table of contents

Page 2.....	Major Components and Hardware List
Page 3.....	Getting Started
Page 4-6.....	Delrin Bushings
Page 7.....	Front Dual Rate Coil Spring
Page 8-10.....	Front HQ Series Shocks
Page 11-13.....	Front Sway Bar
Page 14-24.....	Composite Leaf Spring
Page 25-27.....	Rear HQ Series Shocks

THIS KIT WILL FIT CORVETTES WITH 2 1/4" OR 2 1/2" LEAF SPRINGS. MEASURE THE WIDTH OF YOUR LEAF SPRING AND FOLLOW THE CORRECT STEPS FOR MOUNTING YOUR LEAF SPRING. 63-77 CORVETTES HAVE 2 1/4" SPRINGS FROM FACTORY, 78 CORVETTE CAN HAVE 2 1/4" OR 2 1/2", 79-82 CORVETTES HAVE 2 1/2" LEAF SPRINGS.



Major ComponentsIn the box

Part #	Description	QTY
55480710	Front Coil Springs	2
	Composite Rear Leaf Spring Kit	
90001397	Composite Leaf Spring	1
90001400	1" Clamping Block	1
90001401	Clamping Block Side Plates - 2 1/2" wide leaf spring cars	2
90001393	Leaf Spring Linkage Bolt	2
90001394	Leaf Spring Bushing Kit	1
90001391	Leaf Spring Height Adjustment Spacer	2
	Front Control Arm Delrin Bushing Kit	
70012382	Delrin Bushing Outer Shell - Upper Control Arm	4
70012517	Delrin Bushing Outer Shell - Lower Control Arm	4
90002521	Delrin Bushing Inner Sleeve - Upper Control Arm	4
90002538	Delrin Bushing Inner Sleeve - Lower Control Arm	4
70012419	Delrin Bushing - Upper Control Arm	4
70012572	Delrin Bushing - Lower Control Arm	4
99373006	3/8" Split Lock Washer	4
99433009	7/16" Split Lock Washer	4
90002263	Red Loctite	1
	Front Shocks	
986-10-043	5.25" Stroke Stud Top Shock - Front	2
70011139	5/8" ID Shock Bushing (Installed in Shock) - Front	2
90002068	Extended T-bar (Installed in Shock) - Front	2
70011140	Stud Top Bushing - Front	4
70011141	Stud Top Bushing Washer - Front	4
99372006	3/8"-24 Jam Nut - Front	4
85000020	5/64" Hex Wrench	1
	Rear Shocks	
986-10-036	4.75" Stroke Eyelet Top Shock - Rear	2
70011138	3/4" ID Shock Bushing (Installed in Shock) - Rear	4
90002103	5/8" ID Shock Sleeve (Installed in Shock Eyelet) - Rear	2
70011195	7/16" ID Shock Sleeve (Installed in Shock Body) - Rear	2
11539120	Front Swaybar Kit	1



Getting Started.....

Congratulations on your purchase of the Ridetech StreetGrip Kit. This system has been designed to give your car excellent ride and handling along with a lifetime of enjoyment. Some of the key features of this kit include: Dual Rate Coil Springs, Composite Leaf Spring, Delrin Control Arm Bushings, Larger Swaybar with Delrin Liners, and HQ Series Shocks.

The majority of the StreetGrip components will be installed together. For example, the Front Coil Springs, Control Arm Bushings and Shocks will be installed in conjunction with each other. On the rear, the Leaf Springs, and Shocks will be installed in conjunction with each other. The front Sway Bar will need to be ATTACHED to the frame AFTER the rest of the front components are installed.

If you have never done this type of work before, we recommend getting a Factory Service Manual for proper procedures of disassembly and reassembly of the components for your car.

Hardware Kits

The StreetGrip Kit is supplied with a hardware kit. This hardware kit contains individual bags for the different kits within the main kit. The bags are labeled to help determine the correct hardware for the installation of the specific kits. The instructions will aid you in selecting the correct hardware for each component. The bags included in this kit are:

Front Sway Bar Kit: 99010147

Composite Leaf Spring Hardware: 99010146

Front Suspension

The front components that will need to be installed are: Control Arm Bushings, Coil Springs, and Shocks. The Sway Bar can be installed anytime after the rest of the front suspension is complete.

Rear Suspension

The rear components that will be installed are; rear Composite Leaf Spring, and rear HQ Series Shocks.

Alignment Specs

Anytime you change suspension components, you should have the car alignment checked.

Suggested Alignment Specs:

Camber: Street: -.5 degrees

Caster: Street: +3.0 to + 5.0 degrees

Toe: Street: 1/16" to 1/8" toe in



Part # 11539590 - 1963-1982 Corvette Delrin Control Arm Bushings



Recommended Tools

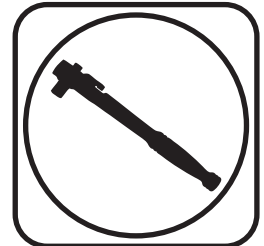

1963-1982 Corvette Delrin Control Arm Bushings Installation Instructions

Table of contents

Page 5..... Included Components and Hardware List

Page 6..... Bushing Installation





Major ComponentsIn the box

Part #	Description	QTY
70012382	Upper Control Arm Bushing Outer Shell	4
70012517	Lower Control Arm Bushing Outer Shell	4
70012419	Delrin Upper Control Arm Bushing	4
70012572	Delrin Lower Control Arm Bushing	4
90002521	Upper Bushing Inner Sleeve	4
90002538	Lower Bushing Inner Sleeve	4

Hardware

Part #	Description	Usage	QTY
99433009	7/16" Split Lock Washer	Lower Control Arm Shaft Bolts	4
99373006	3/8" Split Lock Washer	Upper Control Arm Shaft Bolts	4
90002263	Red Loctite	Control Arm Shaft Bolts	1

Getting Started.....

The Front Control Arms will need to be removed from the car. Refer to the Factory Service Manual for disassembly procedure.

This Corvette Bushing Kit contains: 4 Upper Control Arm Bushing Assemblies and 4 Lower Control Arm Bushing Assemblies. The Upper Bushings are all the same and the Lower Bushings are the same. Be sure to match the correct Bushings with the correct locations.

There are several different ways that the Bushings can be removed from the Control Arms. If you have an air chisel, a wide flat bit works well. If you don't have access to an air chisel, they can be removed by first, drilling out the rubber with a hand drill and drill bit. With the rubber removed, distort the Bushing Shell with a hammer and chisel and knock it out. No matter the process used, the main objective is to **NOT** distort the Control Arm.

WE RECOMMEND MARKING DRIVER AND PASSENGER CONTROL ARMS AND CROSS SHAFTS. ALSO, MARK THE ORIENTATION OF THE CROSS SHAFTS.

1. Measure and record the outside width of the Control Arms before starting Bushing Removal. Should you encounter any fitment issues upon reinstalling the Control Arms, you may need to reference this dimension.

The Cross Shaft must be put in place and in the correct orientation before installing the Bushing Shells in the Upper & Lower Control Arms.

Just like Bushing Removal, there are several ways the Delrin Bushing Assemblies can be installed. No matter the method used, the Control Arm needs to be **SUPPORTED** to keep from distorting the Control Arm. We recommend cutting spacers to go inside the Control Arms when using a press to install the bushings. We have used several different methods to install the Bushing Assemblies. We are going to cover the one that worked best for us. When installing the bushings, the Outer Shell will be installed in the arm by itself. Next, press in the Delrin Bushing, Inner Sleeve as an assembly. **WE DO NOT RECOMMEND INSTALLING THE BUSHINGS COMPLETELY ASSEMBLED.**



Delrin Bushing Installation

Note: The Delrin is self-lubricating, no lubricant is needed.

2. When installing Bushings in the Control Arms, insert the Cross Shaft before installing any Bushings. Support the Back Side of the Flange the Bushing is being Installed in. Use a STIFF piece of Metal clamped in a Bench Vise for the Lower Control Arms (Figure 2). The Upper Control Arm can be supported by either the same piece of Metal or by the Bench Vise with the Jaws opened wide enough to let the Bushing Shell pass through (Figure 3).

3. Use another Piece of Metal or Strong Wood to Drive the Outer Shell into the Control Arm until the Shell stops against the Control Arm.

4. Press the Inner Sleeve into the Delrin Bushing.

5. Start the Delrin Bushing/Inner Sleeve assembly into the outer shell installed in the control arm (Figure 4). Align the cross shaft in the inner sleeves as you insert them. Tap the Delrin Bushing/Inner Sleeve into the shell until the outer lip of the delrin bushing seats against the outer shell. **TAP THE BUSHING IN USING THE CENTER OF THE BUSHING.**

6. Reinstall the Outer Washer using the OEM bolt, but replace the lock washer with the supplied Lock washer and apply Loctite to the threads. Tighten hardware to eliminate any gaps between the Bushings and Cross Shaft.

7. Reattach the Control Arms to the car using the OEM hardware.

8. Attached the spindle to the upper ball joint. Leave the lower arm disconnected to install the Coil Spring.

Torque Specs:

Upper Control Arm Mounting:	50 ftlbs
Lower Control Arm Front Mounting:	70 ftlbs
Lower Control Arm Rear Mounting:	100 ftlbs
Upper Ball Joint:	45 ftlbs, tighten to align cotter pin
Upper Bushing Bolt:	35 ftlbs
Lower Bushing Bolt:	55 ftlbs

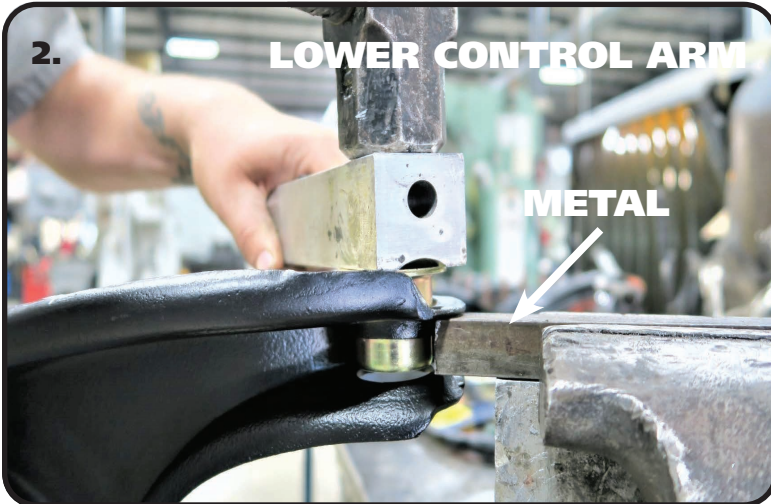



Part # 11532350 - 1963-1982 Corvette Front Coil Spring



Recommended Tools

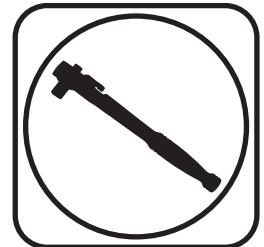

1963-1982 Corvette Front Coil Springs Installation Instructions

Coil Spring # 55480710 Installation

Front dual-rate spring will allow the vehicle to traverse small road irregularities via a soft spring rate. When the vehicle compresses the spring far enough (through large bumps or cornering), it transitions to the firmer spring rate to control the bump or body roll. We have worked closely with Hyperco to develop custom dual rates to ensure the best ride possible.

The Front Control Arm Bushings should be installed before installing spring. The Front Suspension should be assembled with the Lower Ball Joint disconnected from the spindle.

1. Compress the Coil Spring with an Internal Spring Compressor. **TIGHTLY-SPACED COILS TO THE BOTTOM.**
2. With the OEM Spring Removed, insert the Coil Spring into the Pocket. **SPECIAL ATTENTION NEEDS TO BE PLACED ON THE LOCATION OF THE ENDS OF THE SPRINGS TO MAKE SURE THEY ARE CLOCKED CORRECTLY .** The end of the Coil Spring will nest into the receiver area of the Control Arm. If you line up the bottom, the top will be correct.
3. While holding the spring in place, slowly jack the Lower Control Arm up until the Lower Ball Joint can be engaged into the spindle. Install the Castle Nut and Torque to 75 ftlbs, then tighten as needed to align cotter pin hole. Install Cotter Pin. Once the Ball Joint is tight, remove the Spring Compressor.
4. Continue to front shock installation on the next page.





Part # 22159847 - 1963-1982 Corvette HQ Series Shocks



Recommended Tools

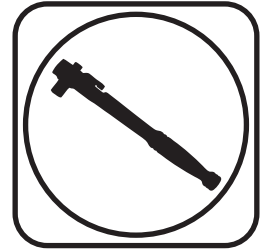

1963-1982 Corvette HQ Series Shocks Installation Instructions

Table of contents

- Pages 9..... Included Components
- Pages 10..... Front HQ Shocks Installation





1963-1982 Corvette HQ Front Smooth Body Shocks

Major ComponentsIn the box

Item #	Part #	Description	QTY
1	986-10-043	5.25" Stroke Shock	2
2	70011139	5/8" ID Shock Bushing	2
3	90002068	Wide Trunnion	2
4	70011141	Bushing Support Washer	4
5	70011140	Stem Bushing	4
6	99372006	3/8"-24 Thin Jam Nut	4
	85000020	5/64" Hex Wrench - for Adjuster Knob Set Screw	1

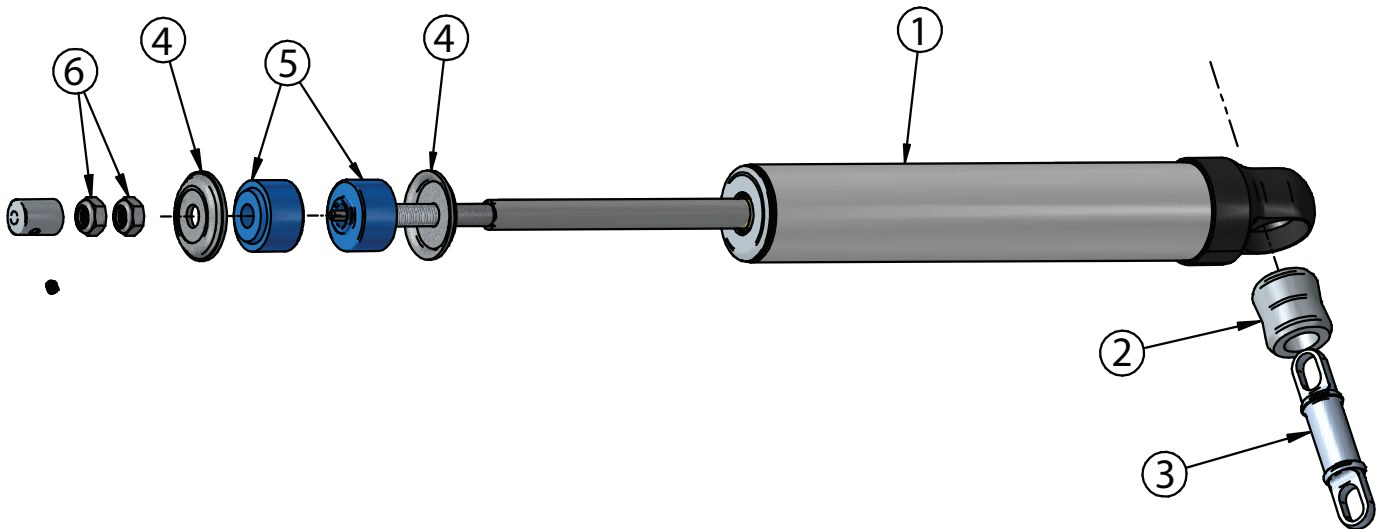



Front Shock Installation

1.

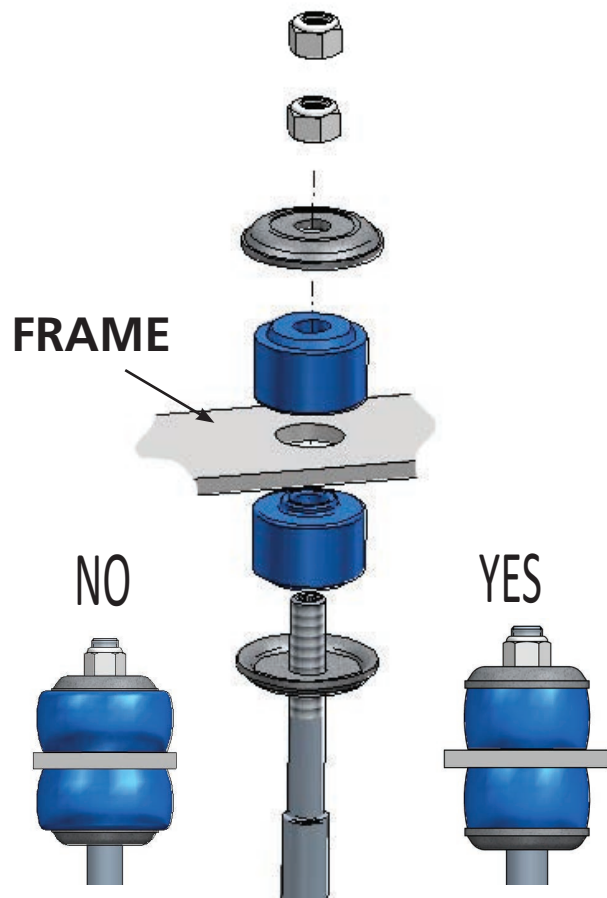

1. With the OEM shock removed, install the Ridetech shock. Remove the adjuster knob by loosening the set screw using the supplied Hex Key. Install a Bushing Support Washer on to the shock shaft followed by a Shock Stem Bushing. Insert the assembly through the factory shock hole in the frame. With the shock stud sticking through the frame, install a Shock Stem Bushing on to the shock stud followed with a Bushing Support Washer. Install a 3/8"-24 Thin Jam nut onto the threads and tighten to 35 inlbs. The Bushing should be tight, but not to the point that the bushing is bulging past the Support Washer. Install the 2nd 3/8"-24 Thin Jam nut and tighten it against the first nut. Reinstall the Adjuster Knob, align the set screw with the FLAT side of the adjuster shaft that is sticking out of the top of the shock shaft.

2.

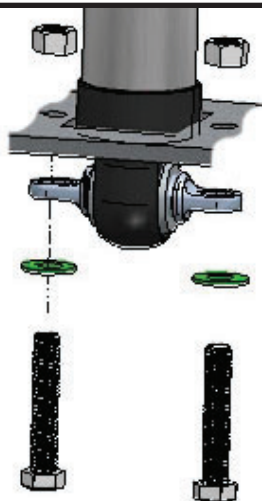

3. Attach the Trunnion to the OEM Control arm using the OEM hardware. It may be necessary to rotate the Trunnion to get it in the correct position. This can be done by sticking a screwdriver in one of the slots and spinning the trunnion in the shock bushing. Torque lower shock bolts to 17 ftlbs.



Part # 11539120 - 1963-1982 Corvette Front Sway Bar



Recommended Tools

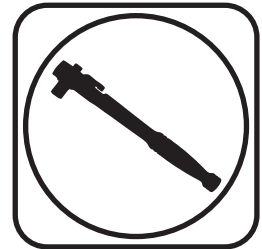

1963-1982 Corvette Front Sway Bar Installation Instructions

Table of contents
Page 2..... Included Components and Hardware List
Page 13-14..... Sway Bar Installation

Hardware Torque Specifications
5/16"-18..... 17 ftlbs

Major ComponentsIn the box

Part #	Description	QTY
90001354	Front Sway Bar	1
90002931	End Link Kit	2
70012402	Delrin Sway Bar Bushing Liner	2
90002533	Bushing Strap	2
90002539	Sway Bar Bushing	2
90002534	Bushing Frame Spacer - C2 ONLY	2
70014721	Locking Ring	2

HARDWARE KIT #99010147

QTY	Part Number	Description
BUSHING MOUNTING		
4	99311030	5/16" -18 x 1" Hex Bolt
4	99313001	5/16" Flat Washer
4	99373005	5/16" Split Lock Washer

Getting Started.....

This Sway Bar Kit utilizes a Delrin Liner in the Sway Bar Bushing. The Delrin Liner allows the Sway Bar to move freely and quietly in the Bushing. The Delrin is self-lubricating, no lubrication is required.

1. **Jack the vehicle up to a safe working height and support with jack stands. Make sure the jack stands are stable before working under the car.**
2. Remove the stock sway bar.

3.



3. Open the Delrin Liner at the split and slip it over the Sway Bar. Position it in the area that the bushing will ride based on the location of the stock swaybar. Do this on both ends of the swaybar.

4.



4. Open the Sway Bar Bushing at the split and slide it **OVER** the Delrin Liner. Do this on both Delrin Liners.

5.



5. The Bushing Straps have the mounting holes that are offset. **The Mounting Holes need to be closest to the bend of the sway bar.** Slip the Bushing Straps over the Sway Bar Bushings.

6.



6. Slide the Sway Bar into position on the car. The sway bar is installed in the OEM location. You may need to move the bushing/straps on the sway bar to line them up with the OEM mounting holes.



7. C2 ONLY!!!

7. C2 ONLY!!! The C2 Corvette requires a Spacer to be used between each Sway Bar Bushing and the frame. Be sure to get the offset the same direction as the bushing strap. The holes should be offset toward the bend of the sway bar.



8.

8. Again, the mounting holes need to be closest to the bend off the sway bar.. Install a 5/16" Lock Washer & 5/16" Flat Washer on (2) 5/16"x 1" Hex Bolts. Insert the hardware through the OEM swaybar mounting holes, threading the hardware in to the mount. Do NOT tighten the mounting hardware at this time.



9.

9. Install the End Links using **Diagram 1** as a reference. Install both end links before tightening the end link hardware. Tighten the end link barrel nut until it is flush with the end of the bolt, and then tighten it 2-3 more complete rounds.

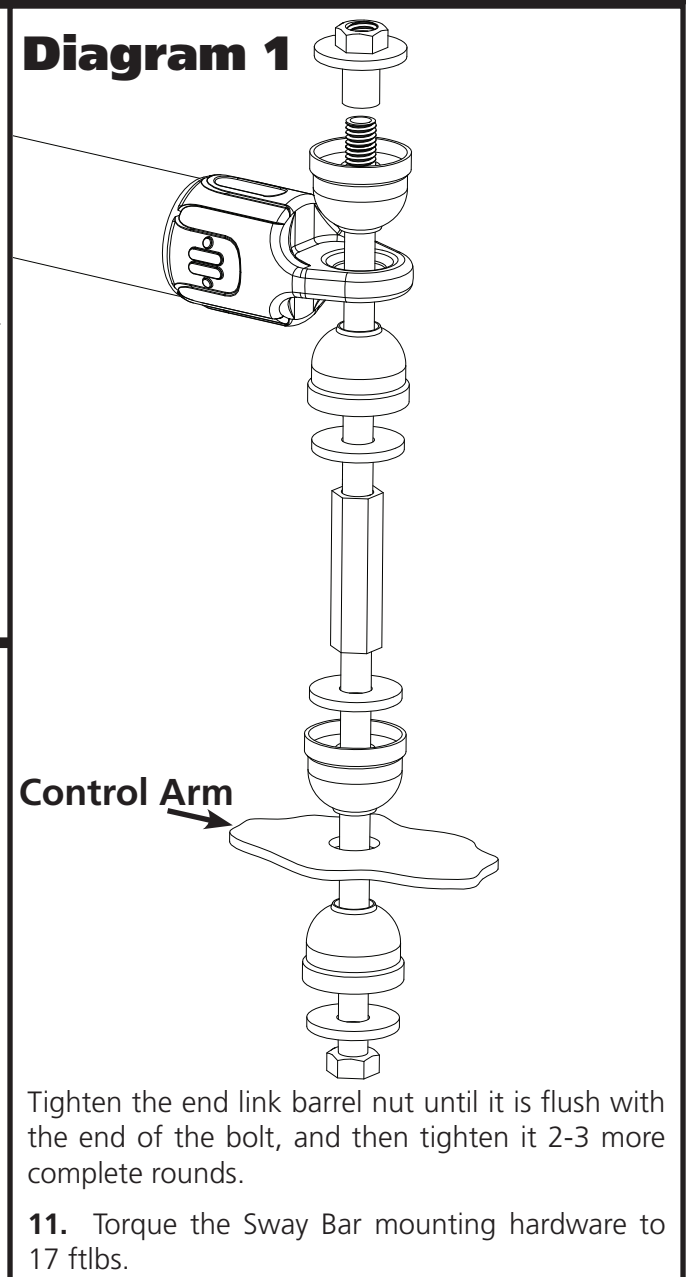

Tighten the end link barrel nut until it is flush with the end of the bolt, and then tighten it 2-3 more complete rounds.

11. Torque the Sway Bar mounting hardware to 17 ftlbs.



10.

10. Install the Locking Rings on the sway bar. They will be positioned against the inside of the sway bar bushings. You will need to disassemble the locking rings to install them on the sway bar. Tighten the hardware with a hex wrench.



Part # 11534799

1963-1982 Corvette Composite Leaf Springs



Recommended Tools

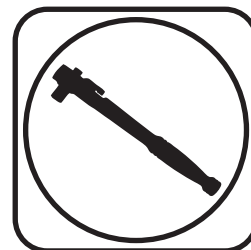
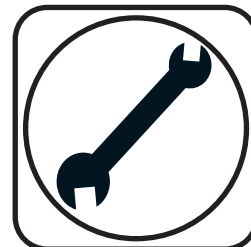

1963-1982 Corvette Composite Leaf Springs Installation Instructions

Table of contents

Page 15.....	Included Components and Hardware List
Page 16.....	Getting Started and Disassembly
Page 17.....	63-78 2 1/4" Leaf Spring Mounting
Page 18-19.....	78-79 2 1/2" Leaf Spring Mounting
Page 19-21.....	80-82 Batwing Leaf Spring Mounting
Page 21-23.....	Leaf Spring Linkage Installation
Page 24.....	Ride Height Adjustment

IT IS VERY IMPORTANT THAT NOTHING COMES IN CONTACT WITH THE COMPOSITE LEAF SPRINGS.

THIS KIT WILL FIT CORVETTES WITH 2 1/4" OR 2 1/2" LEAF SPRINGS. MEASURE THE WIDTH OF YOUR LEAF SPRING AND FOLLOW THE CORRECT STEPS FOR MOUNTING YOUR LEAF SPRING. 63-77 CORVETTES HAVE 2 1/4" SPRINGS FROM FACTORY, 78 CORVETTE CAN HAVE 2 1/4" OR 2 1/2", 79-82 CORVETTES HAVE 2 1/2" LEAF SPRINGS.





Major ComponentsIn the box

Part #	Description	QTY
90001397	Leaf Spring Blade	1
90001400	1" Leaf Spring Clamping Block	1
90001401	Spacer Block Side Plates - 2 1/2" wide leaf spring cars	2
90001393	Leaf Spring Bolt (9.5")	2
90001394	Leaf Spring Bushing Kit	1
90001391	Leaf Spring Bolt Spacers	4

Hardware Kit #99010146

QTY	Description
LEAF SPRING TO TRAILING ARM	
2	1/2"-20 Slotted Nut
2	1/8" Cotter Pin
4	1/2" ID x 2" OD Washer
LEAF SPRING SPACER BLOCK	
4	1/4"-20 X 1/2" Button Head Cap Screw

QTY	Description
LEAF SPRING MOUNTING	
4	7/16" Split Lock Washer
1	7/16"-14 x 1 1/4" Hex Bolt GR8
4	7/16"-14 x 3 1/4" Hex Bolt GR8
4	9/16" Split Lock Washer
4	9/16"-12 x 3 1/4" Hex Bolt GR8

Height Options

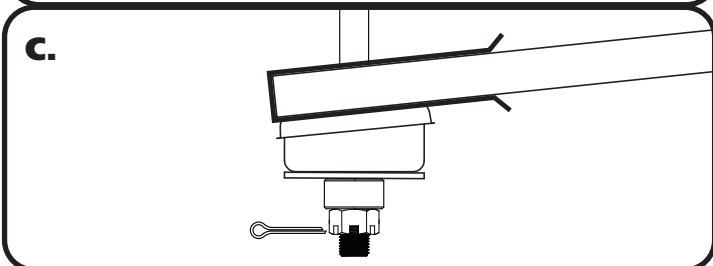

!HEIGHT OPTIONS!

This kit has some height options and adjustment ability, depending on the stance you are after. The 1" Clamping Block can be mounted above **(A)** or below **(B)** the leaf spring. The kit also includes [4] 1/2" spacers that can be installed on the leaf spring bolt **(C)** to raise the rear of the car.

If you are looking for a level car, start with the block on the bottom side of the leaf spring. If you like the rear of the car higher, put the block on the top side of the leaf spring. The leaf spring bolt spacers are 1/2" tall and will change the ride height approximately 3/8" per set of spacers.

We also offer a coil spring spacer #90001395 to raise the front, if needed.



Getting Started.....

IT IS VERY IMPORTANT THAT NOTHING COMES IN CONTACT WITH THE COMPOSITE LEAF SPRING.

DEPENDING ON HOW YOUR EXHAUST SYSTEM IS ON YOUR CORVETTE, YOU MAY HAVE TO REMOVE IT TO INSTALL THE REAR LEAF SPRING.

1. Jack the car up and support it by the frame rails. You may need to raise and lower the trailing arms with a jack to ease installation. With the car supported by the frame, put the jack underneath the rear of the trailing arm. Raise the jack enough to take pressure off the shock. Disconnect the bottom of the shock, retaining the OEM hardware. Repeat on the other side.

Disassembly



2. Use the jack to raise one end of the leaf spring enough to take tension off the leaf spring linkage bolt. Remove the linkage. Slowly release the jack. Repeat on the other side.



3. With both ends of the leaf spring disconnected from the trailing arms, remove the center clamping plate. Retain the clamping plate for installation of the new leaf spring. On 80-82 Corvettes, you will need to remove the shield that is below the leaf spring clamp.

INSTALLATION IS GOING TO DEPEND ON THE WIDTH OF THE LEAF SPRING. IF YOUR CAR HAS A 2 1/4" WIDE LEAF SPRING, CONTINUE WITH STEP 4. IF YOU 78-79 CORVETTE AND IT HAS A 2 1/2" WIDE LEAF SPRING, SKIP TO STEP 7. IF YOU ARE INSTALLING THE LEAF SPRING ON AN 80-82 CORVETTE, SKIP TO STEP 12.



63-78 2 1/4" Leaf Spring Mounting



4. **63-78 CORVETTE WITH 2 1/4" LEAF SPRING!** Position the leaf spring in the OEM location with the ends of the leaf spring pointing downward. THE CENTER LOCATING PIN NEEDS TO BE INDEXED INTO THE HOLE OF THE HOUSING.



5. **63-78 CORVETTE WITH 2 1/4" LEAF SPRING!** The kit contains a 1" thick clamping block that needs to be positioned between the composite leaf spring and OEM clamping plate. The clamping block has a center hole that the leaf spring pin will nest into. The pin of the clamping block will be pointing down.



6. **63-78 CORVETTE WITH 2 1/4" LEAF SPRING!** The kit contains new hardware for the center clamping plate. Depending on the year of the car, it can have one of 2 bolts sizes, 9/16"-12 or 7/16"-14. The kit contains (4) 3 1/4" long bolts & (4) Split lock washers of each size. Determine which is the correct size for your Corvette. Hold the center of the leaf spring and 1" clamping block in position. Bolt the OEM clamping plate in place with the correct hardware. Snug the hardware down, but **DO NOT COMPLETELY TIGHTEN**. The car needs to have its weight on the rear tires before torquing the clamping bolts. **SKIP TO STEP 17.**



78-79 2 1/2" Leaf Spring Mounting

7.

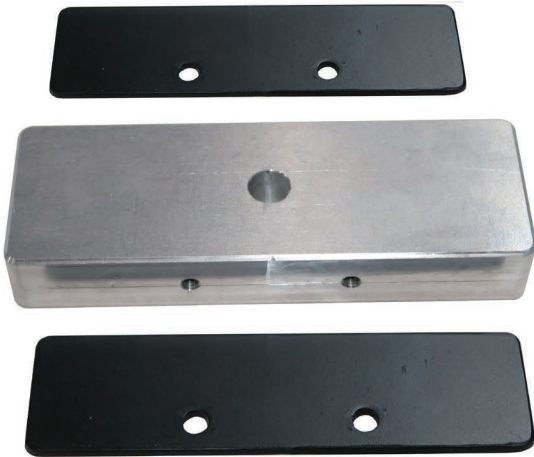

7. 78-79 CORVETTE WITH 2 1/2" LEAF SPRING! The kit includes a 1" clamping block and 2 side plates for installing the leaf spring in a car that came originally equipped with a 2 1/2" wide leaf spring.

8.



8. 78-79 CORVETTE WITH 2 1/2" LEAF SPRING! Attach the side plates to the clamping block using (4) 1/4"-20 x 1/2" button head screws. The mounting holes in the clamping block are centered, the tabs can go either direction, but need to be sticking up on the opposite side of the locating pin. Attach the tabs so they are both sticking above the spacer block the same direction, opposite of the locating pin. Align the holes in the side plates with the holes in the clamping block. Thread a 1/4"-20 x 1/2" button head in each hole. Torque to 4 ftlbs (48 inch lbs).

9.



9. 78-79 CORVETTE WITH 2 1/2" LEAF SPRING! Slip the clamping block assembly on the bottom side of the leaf spring, aligning the locating pin with the hole in the clamping block assembly. The clamping block assembly needs to be installed on the leaf spring with the side plates going on each side of the leaf spring. The locating pin in the clamping block should be pointing down away from the leaf spring. The leaf spring is mounted in the car with the ends curving to the ground.



78-79 2 1/2" Leaf Spring Mounting



10. 78-79 CORVETTE WITH 2 1/2" LEAF SPRING! Position the leaf spring/clamping block in the OEM location with the ends of the leaf spring pointing downward. THE CENTER LOCATING PIN NEEDS TO BE INDEXED INTO THE HOLE OF THE HOUSING.

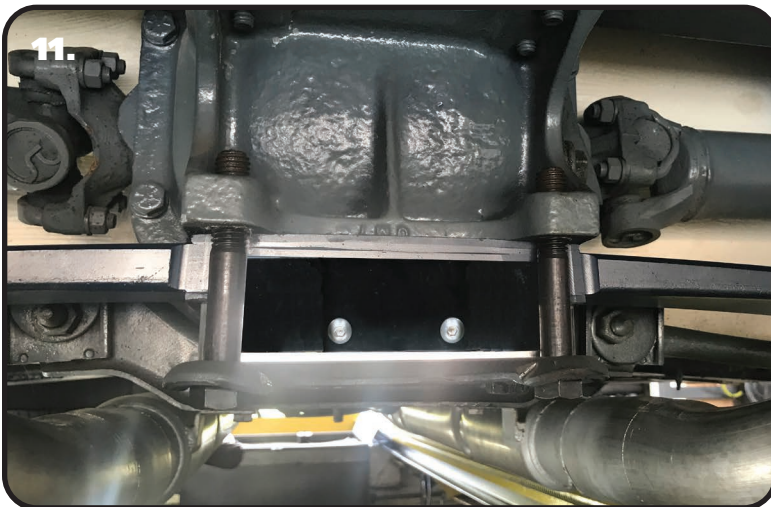

11. 78-79 CORVETTE WITH 2 1/2" LEAF SPRING! The kit contains new hardware for the center clamping plate. The kit contains (4) 7/16"-14 x 3 1/4" bolts & (4) 7/16" split lock washers. Hold the center of the leaf spring and clamping block assembly in position. Bolt the leaf spring/clamping plate in place with the supplied hardware. Snug the hardware down, but **DO NOT COMPLETELY TIGHTEN**. The car needs to have its weight on the rear tires before torquing the clamping bolts. **SKIP TO STEP 17.**

80-82 Batwing Leaf Spring Mounting



12. 80-82 CORVETTE! The kit includes a 1" clamping block and 2 side plates. The 80-82 Corvette will only use 1 side plate installed to the rear of the car.



80-82 Batwing Leaf Spring Mounting

13.



13. 80-82 CORVETTE! Attach the (1) side plate to the clamping block using (2) 1/4"-20 x 1/2" button head screws. The mounting holes in the clamping block are centered, the tab can go either direction, but needs to be sticking up on the opposite side of the locating pin. Attach the tab so it is sticking above the block on the opposite side as the locating pin. Align the holes in the side plate with the holes in the clamping block. Thread a 1/4"-20 x 1/2" button head in each hole. Torque to 4 ftlbs (48 inch lbs).

14.

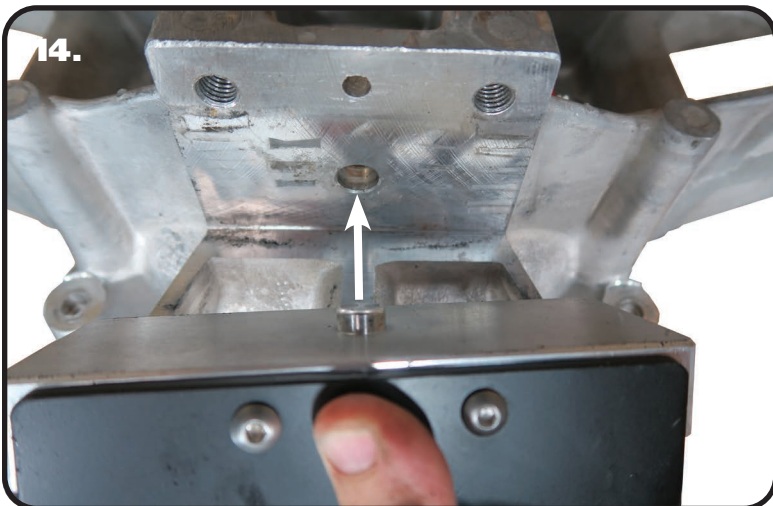

14. 80-82 CORVETTE! Position the clamping block in the OEM location with the side plate to the REAR of the car and pointing down. THE CENTER LOCATING PIN NEEDS TO BE INDEXED INTO THE HOLE OF THE HOUSING.

15.



15. 80-82 CORVETTE! Hold the clamping block in place and put the leaf spring in place. THE CENTER LOCATING PIN NEEDS TO BE INDEXED INTO THE HOLE OF THE CLAMPING BLOCK.



80-82 Batwing Leaf Spring Mounting

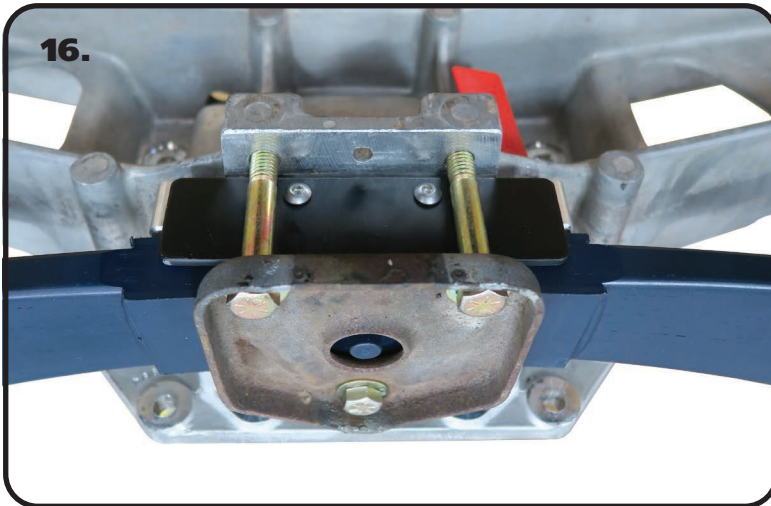

16. 80-82 CORVETTE! The kit contains new hardware for the center clamping plate. The kit contains (2) 7/16"-14 x 3 1/4" bolts, (1) 7/16"-14 x 1 1/4" bolt & (3) Split lock washers. Hold the center of the leaf spring and clamping block assembly in position. Bolt the clamping plate in place with the supplied hardware. Snug the hardware down, but **DO NOT COMPLETELY TIGHTEN**. The car needs to have its weight on the rear tires before torquing the clamping bolts. Reinstall the shield below the clamping plate.

Leaf Spring Linkage Installation

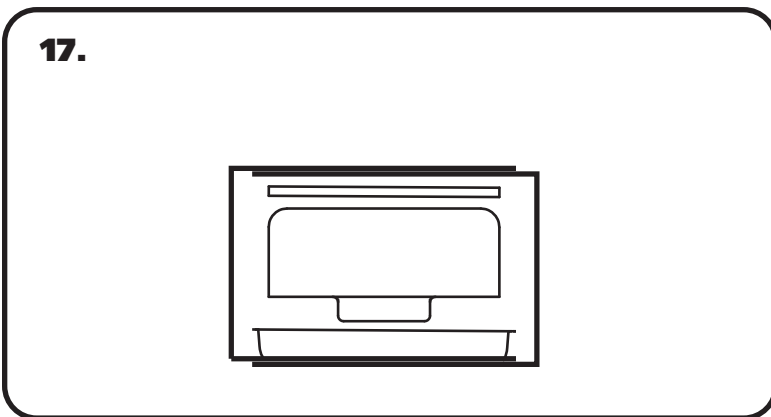

17. Install a leaf spring bushing into the OEM location of the trailing arm. Install a 1/2" ID x 2" OD flat washer on top of the leaf spring bushing, lining up the center holes.

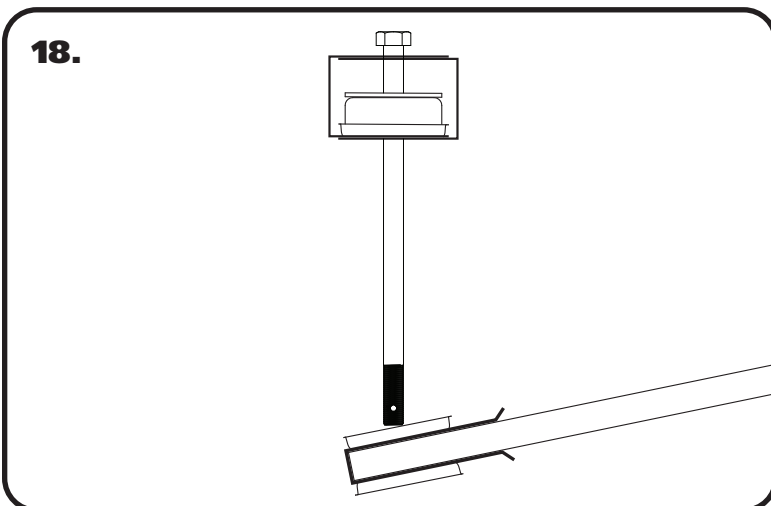

18. Insert the 1/2"-20 x 9 1/2" bolt in the leaf spring bushing. The bolt will go in through the top of the trailing arm.



Leaf Spring Linkage Installation

19.

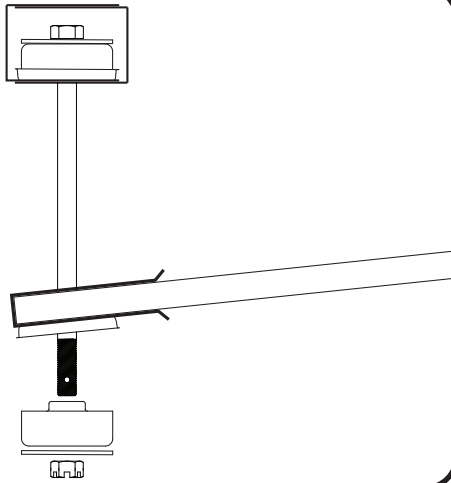

19. You will need to raise the end of the leaf spring up to get the bolt through far enough to get the bottom leaf spring bushing installed. Make sure to jack up the leaf spring by the metal on the end of the spring. **DO NOT JACK ON THE COMPOSITE PART OF THE LEAF SPRING.**

20.

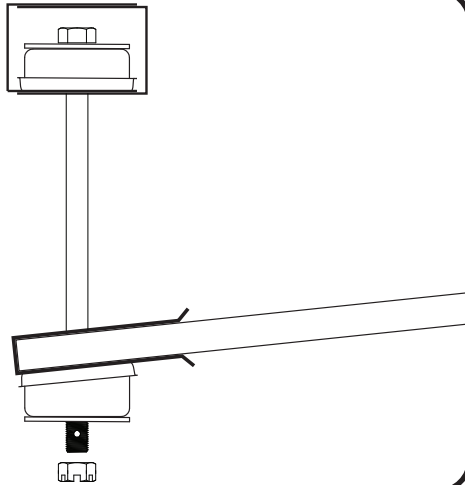

20. Slip the lower leaf spring bushing on the threads of the bolt sticking through the leaf springs, followed by the 1/2" ID x 2 OD washer.

21.

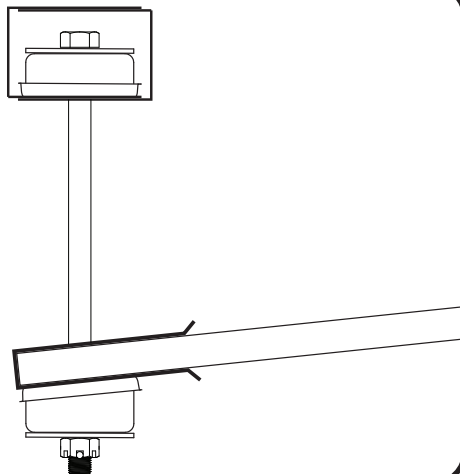

21. While holding the bushing and washer in place, thread the 1/2"-20 slotted hex nut on the bolt sticking through the bushing/washer. Thread the nut up the bolt until the cotter pin hole lines up with a slot in the nut.



Leaf Spring Linkage Installation

22.

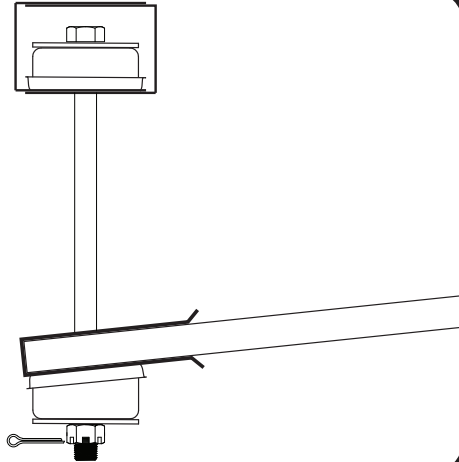

22. Install the 1/8" cotter pin and bend the ends to keep it in place.

23. Continue with the rear shock installation.

Ride Height Adjustment (OPTIONAL)

24.

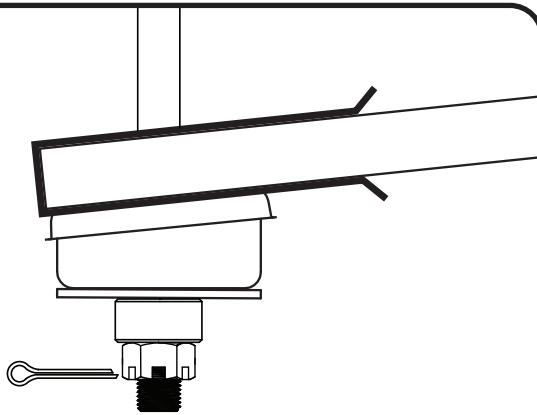

24. **OPTIONAL** The kit includes spacers that will raise the back of the car approximately 3/8". The spacer will get installed between the 1/2"-20 Slotted hex nut and the washer of the lower leaf spring bushing. Support the end of the leaf spring by the metal part of the blade. Remove the cotter pin and 1/2" slotted hex nut. Install the spacer, followed by the castle nut and cotter pin. You will need to raise the end of the leaf spring more to get the cotter pin hole aligned with the slots of the slotted hex nut. We include 2 spacers per side for fine tuning your rear ride height.



Part # 22149857 - 1963-1982 Corvette HQ Series Shocks



Recommended Tools

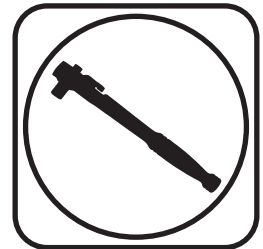

1963-1982 Corvette HQ Series Shocks Installation Instructions

Table of contents

- Page 25..... Included Components
- Page 25-26..... Rear Shock Installation
- Page 27..... Shock Adjustment





1963-1982 Corvette HQ Rear Smooth Body Shocks

Major ComponentsIn the box

Item #	Part #	Description	QTY
1	986-10-036	4.75" Stroke HQ Series Shock	2
2	70011138	3/4" ID Shock Bushing	4
3	90002103	.625 ID Shock Sleeve	2
4	70011195	.437" ID Shock Sleeve	2

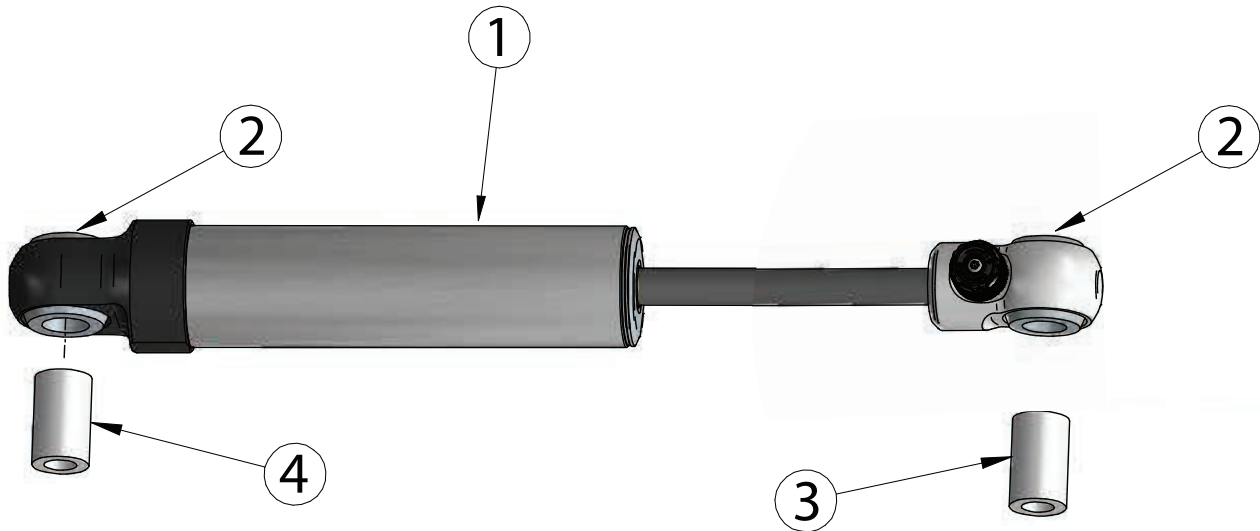

Shock Installation



1. Completely remove the old rear shock.
2. Attach the new shock to the OEM frame mount with the shock body up. Use the OEM hardware to attach the shock. Torque hardware to 60 ftlbs.



Rear Shock Installation



3. Jack the trailing arm up to align the shock eyelet with the OEM stud. Attach the shock eyelet to the OEM shock stud. To ease adjustment, position the adjuster knob to the front of the car. Use the OEM hardware to attach it. Torque the nut to 40 ftlbs.

4. Set the car on the ground and torque the leaf spring clamping plate mounting bolts to 65 ftlbs.

5. Check all hardware to make sure everything is tight.



Shock Adjustment

Shock adjustment 101- Single Adjustable

Rebound Adjustment:

How to adjust your new shocks.

The rebound adjustment knob is located on the top of the shock absorber protruding from the eyelet or stud top. You must first begin at the ZERO setting, then set the shock to a street setting of 12.



-Begin with the shocks adjusted to the ZERO rebound position (full stiff). Do this by rotating the rebound adjuster knob clockwise until it stops.

-Now turn the rebound adjuster knob counter clock wise 12 clicks. This sets the shock at 12. (settings 21-24 are typically too soft for street use).

Take the vehicle for a test drive.



-if you are satisfied with the ride quality, do not do anything, you are set!

-if the ride quality is too soft increase the damping effect by rotating the rebound knob clock wise 3 clicks.

Take the vehicle for another test drive.



-if the vehicle is too soft increase the damping effect by rotating the rebound knob clock wise 3 additional clicks.

-If the vehicle is too stiff rotate the rebound adjustment knob counter clock wise 2 clicks and you are set!

Take the vehicle for another test drive and repeat the above steps until the ride quality is satisfactory.

Note:

One end of the vehicle will likely reach the desired setting before the other end. If this happens stop adjusting the satisfied end and keep adjusting the unsatisfied end until the overall ride quality is satisfactory.